

E-series

Articulated Dump Trucks

B35E | B40E | B45E | B50E • PIN3

Stage V Certified



BELL

E is for evolution

Your business is our business. Bell Articulated Dump Trucks haul more, for longer at the lowest cost-per-ton to deliver more on your profit margins.

As a global leader in Articulated Dump Trucks, Bell Equipment brings you the world class E-series range. The evolutionary E-series is packed with class leading features that deliver production boosting payloads, lower daily operating costs, superior ride quality and uncompromised safety standards.

Bell E-series ADTs will give your business the competitive edge you need.

- Extensive use of high-strength, lightweight materials give these trucks the best payload-to-mass ratios and hauling efficiencies in each class.

- With their oscillating frame and high-floatation tyres, Bell trucks won't leave you stuck on muddy, rutted or hilly terrain.

- The redesigned sound-suppressed cab features fatigue-beating controls, advanced diagnostic monitor and a sealed switch module for convenient, fingertip operation of numerous functions.

- Fuel-efficient emission certified engines deliver clean power without compromise in all conditions. Leading-edge emissions technology ensures rapid engine response and dependable cold-start performance.



The E-series range takes ADT functionality to new industry standards, with customer-focused enhancements and the highest level of automated machine protection available.

Through substantial investments in Research and Development and employing industry leading technology, advancements in the key areas of performance and fuel efficiency – help you to move more material at lower operating costs and environmental impact.

Specifications	B35E	B40E	B45E	B50E
Gross power	320 kW (429 hp)	380 kW (510 hp)	390 kW (523 hp)	430 kW (577 hp)
Operating mass				
Empty	34 019 kg (74 999 lb)	34 596 kg (76 273 lb)	35 479 kg (78 217 lb)	38 287 kg (84 408 lb)
Loaded	67 519 kg (148 854 lb)	73 596 kg (162 251 lb)	76 479 kg (168 607 lb)	83 687 kg (184 498 lb)
Rated payload	33 500 kg (73 855 lb)	39 000 kg (85 980 lb)	41 000 kg (90 390 lb)	45 400 kg (100 090 lb)
2:1 heaped capacity	20,5 m ³ (27 yd ³)	24 m ³ (31 yd ³)	25 m ³ (33 yd ³)	27,5 m ³ (36 yd ³)



Building on pedigree

Building on from the proven D-series platform, Bell Equipment's evolutionary approach to design delivers optimised power-to-weight ratio and legendary fuel efficiency.



- Automatic Traction Control (ATC) is achieved with speed sensors providing feedback to the truck on-board computer. The computer then controls differential lock activation as needed. This coupled with best in class rear suspension travel results in unparalleled off-road ability.

- Automatic retardation slows the truck when the operator backs off the accelerator pedal for more confidence on steep grades.

- An industry leading, fully automatic seven-speed planetary transmission with torque converter lock-up maximises fuel efficiency.

- High-travel suspension keeps all tyres in constant contact with the ground, for optimum traction.

- Electronic common rail fuel system provides high injection pressures even at low engine speed for improved cold-starting ability, low-speed response and reduced emissions.

- Careful engine packaging and front chassis design gives the best approach angle to allow these ADTs to attack steep terrain.

- Improved payloads, faster haul cycles and industry leading fuel economy all help you move more material at a lower-cost-per-tonne than your competitors.

- Optimised payload-to-weight ratio decreases your cost per tonne because more of your fuel cost is spent moving the material, not running the machine.



Planetary powershift transmission optimises shift points to match conditions and vehicle weight while protecting the transmission from operator error and abuse. Allison FuelSense® calibration optimises production and fuel burn.



The transfer case inter-axle differential delivers equal torque to each axle when traction is favourable. When conditions deteriorate, the diff-lock automatically engages to deliver torque to the tyres that can best use it.



High-strength steel and widely spaced taper roller bearings in the articulation area enhance long-term durability.



A tailgate is available as an option for better material retention. The tailgate opens as the bin is raised for dumping. Spring steel straps maintain positive seal throughout the haul, ensuring minimal material is lost.

Our innovative front and rear comfort ride suspension options are offered to even further enhance ride quality and ensure minimal whole body vibration exposure.

Productivity increases through reduced cycle times, and reduced haul road maintenance are even further benefits of these extremely successful systems. Experienced ADT operators who have driven trucks installed with these systems have come away amazed by the comfort of the machine, as well as the confidence that the adaptive front suspension engenders.



Uncompromised durability

Built smarter, to work harder.

Bell ADTs offer optimised machine weights so you spend more time and money moving material and not running the machine.

With decades of ADT experience, the Bell E-series articulated hauler is designed and manufactured using purpose built, reliable Bell components best suited for the toughest of conditions.

The central oscillation joint, high suspension travel on all axles, and balanced weight distribution provide the agility and ability to navigate hostile terrain.



The high-strength steel chassis delivers strength and rigidity without excess weight.

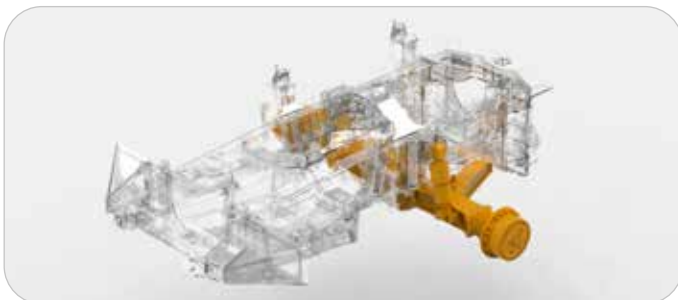

For comfortable productivity, the A-frame suspension system coupled with hydropneumatic suspension struts reduce the lateral vibration often experienced with off-road conditions. A superior suspension seat provides additional isolation for the operator.



Rough terrain demands tough suspensions. Heavy-duty components absorb shocks and come back for more. You get best-in-class suspension travel and ground clearance, too.

- Fully enclosed, flooded, dual circuit wet disc brakes offer superior braking performance and extended service life essential for wet and muddy conditions. Oil-immersed wet-disc brakes are virtually maintenance-free and now feature a high flow circulation system with filtration and cooling.

- Viscous electronically controlled direct-drive engine fans provide cooling for the best efficiency.

- Class leading engine braking, coupled with automated brake retardation, provides superior braking power. Brake retardation is at pressures low enough to ensure no contact between the wet brake plates, and therefore no wear.



Other uptime-boosting features include world class on-board diagnostics with live stream functionality, solid-state sealed switches and satellite fleet management system.

High-strength welded-alloy steel chassis and reinforced articulation joints, offer superior strength and durability with optimised weight for class leading power-to-weight ratio. Lower machine mass reduces powertrain and structural stress.

Run leaner and cleaner

A combination of an optimally tuned engine and weight optimised complete machine package ensure that Bell ADTs have a minimal carbon footprint.

SCR uses AdBlue®/DEF which

- is non-toxic, odorless, low cost and simple to refill.
- is injected into the flow of the exhaust gases and reacts with the NOx gases in the catalytic convertor to form harmless nitrogen and water.
- is consumed at approximately 3-5% of your fuel usage.

EGR

- recirculates burnt exhaust gas back into the combustion chamber, lowering combustion temperatures and NOx production.

DPF

- Our DPF technology has been used in Mercedes-Benz road trucks for over 10 years.
- Regeneration is done during normal operation as much as possible.
- In light applications stationary active regeneration may be necessary.



- Reduced emissions
- Improved engine efficiency
- Lower fuel consumption
- Improved power
- Improved torque
- Improved engine response





- Stage V emissions control coupled with the lowest fuel burn ensures the lowest environmental impact.

Our E-series truck platform easily accommodates current engine and related emissions control technology and reflects our strategy of continuous improvement.

Bell Equipment's evolutionary E-series runs SCR-technology (Selective Catalytic Reduction) in combination with EGR to give an industry leading standard in fuel-efficient emission control, designed specifically for the off-highway market to be compliant to Tier 4f. Engine power and fuel consumption have been further optimised through event dependent software that controls retardation, cooling and charging of accumulators.

Operate with ease

Using the latest in automotive technology and state-of-the-art tooling, the E-series takes operator experience to new heights.

Climb into the cab of a Bell ADT and you will feel right at home. Its quiet, spacious interior, ergonomically positioned operator station and climate-controlled cabin is loaded with productivity boosting comfort and convenience features that minimise operator fatigue and enhance the operator's experience.

Modern flowing lines, in keeping with current styling trends on road vehicles, offer unsurpassed levels of visibility.

From the state-of-the-art 10" full colour screen, automotive mouse interface and sealed switch module with centrally located sealed display unit to air suspension seat, tilt/telescoping steering wheel and optional CD player with high-output speakers, the E-series provides everything your operators need to perform at their best.

- The standard sound-suppression package significantly reduces noise levels and operator fatigue.
- A fully adjustable air-suspension seat with variable damping, auto height adjust according to operator weight, pneumatic lumbar support and multipoint harness for class-leading comfort and safety.
- New machine styling and cabin design improvements, which include full glass access door and high visibility mirror package, provide exceptional all-round visibility.

- The adaptive transmission control adjusts clutch engagement to ensure smooth, consistent shifts throughout the life of the truck.
- A purpose designed HVAC climate control system with automotive-style louvres keeps the glass clear and the cab comfortable.
- You won't find retarder pedals or levers in a Bell truck. Retarder aggressiveness is simply set on the switch pad. Or Hill Descent Control can set it for you automatically.



Easy-to-understand instruments and intuitive controls wrap around the operator so they're easier to view and operate.



A user friendly 10" colour monitor offers vital operating information, safety warnings, detailed diagnostic readings and dump body function settings.



An automotive controller provides menu navigation on the colour monitor to extract information on machine operation and adjustment of machine settings.



Convenient sealed switch module provides fingertip control of numerous productivity enhancing functions including: **Keyless Start, I-Tip, Dump Body Upper Limit, Soft Stop/Hard Stop Selection, Retarder Aggressiveness and Speed Control.**



Safety, our business too

By listening to users and delivering on expectations in an ever changing workplace, we provide a truck that leads in application safety with numerous groundbreaking innovations.

Independent features such as Keyless Start, Hill Assist, Bin Tip Prevention, Auto Park Application (APA), Standard Turbo Spin Protection and On-Board Weighing (OBW) are still standard on the E-series.

For improved safety and productivity, the E-series has Automatic Traction Control (ATC).

- Full handrails (to ISO 2876) can be installed to offer improved safety when performing engine checks.
- The park brake automatically applies when neutral is selected and it is not possible to engage neutral at speed. Torque dependent park brake release (Hill Assist) ensures no roll back on slopes.
- All trucks can be set up to automatically sound the horn when starting or switching between forward and reverse.

- Best-in-class retarder and engine braking automatically applies when the operator lifts his foot off the accelerator. Retarder aggressiveness can be simply adjusted on the sealed switch module ensuring maximum descent control for all conditions.
- Multiple geofencing in challenging site conditions ensures safe machine operation, such as downhill speed control, geofence speed limits and bin restrictions.



Our quiet operator cabins are ROPS/FOPS certified with an air suspension operator seat. The trainer seat has a retractable lap belt while the operator seat has a standard 3 point seat belt. Both have automatically locking retractors.



An optional integrated reverse camera and high visibility mirrors ensure superior all round visibility.



Keyless start, driver identity and access codes ensure no unauthorised operation of your equipment.



The exclusive on-board weighing presents the operator with real time information on the payload while the machine is being loaded. A 'speed restriction' mode can also be activated if the machine is significantly overloaded.



The incorporation of a pitch and roll sensor in the vehicle prevents bin operation if the truck is in an unsafe position.



Both operator or site selectable maximum speed control allows the vehicle to automatically decelerate and apply the retarder to prevent onsite speeding.



Maximise your uptime

The E-series is loaded with features that make it as easy to maintain as it is to operate. Spend less time and expense getting ready for work and more time getting work done.

Easy-to-reach dipsticks, see-through reservoirs, sight gauges and grouped service points make quick work of the daily routine. Quick change filters, extended engine and hydraulic oil-service intervals lower daily operating costs and provide superior machine uptime.

An industry leading 10" colour monitor offers on-board machine diagnostics as well as automated daily service functionality, this coupled with diagnostic test ports help you troubleshoot and make informed maintenance decisions on site.



If something goes wrong, the diagnostic monitor provides service codes and supporting info to help diagnose the problem.



The cab can be tilted in minutes without special tools, for convenient service access to drivetrain components.



An in-cab load centre simplifies fuse replacement. Fewer relays, connectors and harnesses mean higher reliability.



We offer a remote transmission filter option. They make transmission filter replacement a fast and clean task.



- Automated daily service checks can be done with ease and comfort from inside the operator station using the 10" colour LCD monitor and sealed display controller.

- The load-sensing hydraulic system was designed with simplicity in mind, while maintaining efficiency. Fewer components for improved reliability and serviceability.

- Extended engine transmission and hydraulic oil-change for increased uptime and lower operating cost.

- Available environmental drains allow quick, no-spill changes.

- Your Bell Service Centre has the parts and backup you need to stay productive and offers a wide variety of preventative maintenance and support programmes to help you control costs.



See-through fluid reservoirs and sight gauges let you check fluid levels at a glance.



Easily accessible test ports allow technicians to troubleshoot problems more quickly.



The centralised lube bank places difficult-to-reach grease points within reach.

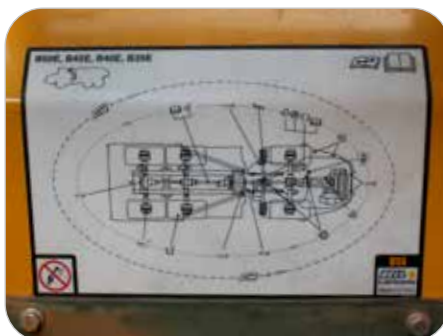

The convenient and easy to understand RSG decal details daily checks and actions (eg: greasing).

Welcome to the ...

BELL Family

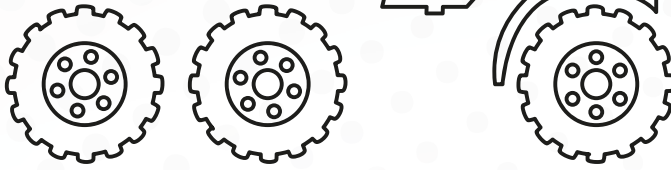

“Power up and plug in to our end-to-end customer solutions!”

START

Through our living motto **‘Strong Reliable Machines, Strong Reliable Support’**, we offer both exceptional equipment and aftermarket support products because we want your Bell ownership experience to be a happy one.



SETTING YOU UP FOR SUCCESS



TRAINING

PROTECTING YOUR ASSETS



LUBE CHECK



MAINTENANCE CONTRACT



EXTENDED WARRANTY



FLEETM@TIC®



KEEPING YOUR MACHINE RUNNING

LUBRICANTS

PARTS

SERVICE KITS

TECHNICAL SUPPORT

SPECIAL TOOLS

BELL OUTLETS

GIVING YOU EXTRA VALUE, LONGER LIFE



REMAN COMPONENTS



PRE-OWNED EQUIPMENT

SUPPORTING YOU EVERY STEP OF YOUR BELL OWNERSHIP EXPERIENCE

Smarter fleet management



BELL
Fleetm@tic®

Cutting edge technology, helping you run your fleet smarter. Providing accurate, up-to-date operational data, production data and diagnostic data.

The key to a productive and profitable fleet, lies in the ability to monitor and manage your machines and operators efficiently. Machine operational data is processed and compiled into useful production and performance statistics, accessible via the Bell Fleetm@tic® website. These reports are also automated and emailed directly to you. The two monitoring packages that we have available, are:

- **The Classic Package** supplies you with good enough information for you to have a very good understanding of how your machines is operating for each shift that it runs. This package comes standard with the machine for 2 years.
- **The Premium Package** is focused on customers who need to have extremely detailed information of the machine's operation. For this package we offer similar information to that of the Classic Package but for each individual laden - unladen cycle. In addition, live tracking is available on the Fleetm@tic® website on a per minute basis.

Fleetm@tic®:

- Maximise productivity
- Generate machine utilisation reports
- Identify operator training requirements
- Pro-active maintenance planning
- Implement safety features
- Receive machine fault codes as well as suggested trouble shooting procedures
- Protect investments
- Receive real time geospatial data



B35E Articulated Dump Truck

ENGINE

Manufacturer
Mercedes Benz (MTU)

Model
OM471LA (MTU 6R 1300)

Configuration
Inline 6, turbocharged and intercooled.

Gross Power
320 kW (429 hp) @ 1 700 rpm

Net Power
301 kW (404 hp) @ 1 700 rpm

Gross Torque
2 100 Nm (1 549 lbf) @ 1 300 rpm

Displacement
12,8 litres (781 cu.in)

Auxiliary Brake
Jacobs Engine Brake®

Fuel Tank Capacity
352 litres (93 US gal)

AdBlue® Tank Capacity
40 litres (11 US gal)

Certification
OM471LA (MTU 6R 1300) meets EU Stage V emissions regulations.

TRANSMISSION

Manufacturer
Allison

Model
4700 ORS

Configuration
Fully automatic planetary transmission.

Layout
Engine mounted

Gear Layout
Constant meshing planetary gears, clutch operated

Gears
7 Forward, 1 Reverse

Clutch Type
Hydraulically operated multi-disc

Control Type
Electronic

Torque Control
Hydrodynamic with lock-up in all gears.

TRANSFER CASE

Manufacturer
Kessler

Series
W2400

Layout
Remote mounted

Gear Layout
Three in-line helical gears

Output Differential
Interaxle 29/71 proportional differential. Automatic inter-axle differential lock.

AXLES

Manufacturer
Bell

Model
30T

Differential
High input controlled traction differential with spiral bevel gears

Final Drive
Outboard heavy duty planetary on all axles.

BRAKING SYSTEM

Service Brake
Dual circuit, full hydraulic actuation wet disc brakes on front and middle axles. Wet brake oil is circulated through a filtration and cooling system.

Maximum brake force:
352 kN (79 133 lbf)

Park & Emergency
Spring applied, air released driveline mounted disc.

Maximum brake force:
206 kN (46 311 lbf)

Auxiliary Brake
Jacobs Engine Brake®. Automatic retardation through electronic activation of wet brake system.

Total Retardation Power
Continuous: 442 kW (593 hp)
Maximum: 834 kW (1 118 hp)

WHEELS

Type
Radial Earthmover

Tyre
26.5 R 25

FRONT SUSPENSION

Semi-independent, leading A-frame supported by hydro-pneumatic suspension struts.

Option: Electronically controlled adaptive suspension with ride height adjustment.

REAR SUSPENSION

Pivoting walking beams with laminated rubber suspension blocks.

Option: Comfort Ride suspension walking beams, with two-stage sandwich block.

HYDRAULIC SYSTEM

Full load sensing system serving the prioritized steering, body tipping and brake functions. A ground-driven, load sensing emergency steering pump is integrated into the main system.

Pump Type
Variable displacement load sensing piston

Flow
330 L/min (87 gal/min)

Pressure
310 Bar (4 500 psi)

Filter
5 microns

STEERING SYSTEM

Double acting cylinders, with ground-driven emergency steering pump.

Lock to lock turns
5

Steering Angle
42°

DUMPING SYSTEM

Two double-acting, single stage, dump cylinders.

Raise Time
11 seconds

Lowering Time
6 seconds

Tipping Angle
70 deg standard, or any lower angle programmable

PNEUMATIC SYSTEM

Air drier with heater and integral unloader valve, serving park brake and auxiliary functions.

System Pressure
8,1 Bar (117 psi)

ELECTRICAL SYSTEM

Voltage
24 V

Battery Type
Two AGM (Absorption Glass Mat) type.

Battery Capacity
2 X 75 Ah

Alternator Rating
28V 80A

MAX. VEHICLE SPEED

1st	4 km/h	3 mph
2nd	9 km/h	6 mph
3rd	16 km/h	10 mph
4th	22 km/h	14 mph
5th	31 km/h	19 mph
6th	42 km/h	26 mph
7th	48 km/h	30 mph
R	7 km/h	4 mph

CAB

ROPS/FOPS certified 72 dBA internal sound level measured according to ISO 6396.

Load Capacity & Ground Pressure

OPERATING WEIGHTS		GROUND PRESSURE*		LOAD CAPACITY		OPTION WEIGHTS	
UNLADEN	kg (lb)	LADEN		BODY	m³ (yd³)	kg (lb)	
Front	16 816 (37 073)	(No sinkage/Total Contact Area Method)		Struck Capacity	16 (21)	Bin liner	1 216 (2 681)
Middle	8 708 (19 198)	26.5 R 25	kPa (Psi)	SAE 2:1 Capacity	20,5 (27)	Tailgate	906 (1 997)
Rear	8 495 (18 728)	Front	361 (52)	SAE 1:1 Capacity	24,5 (32)		
Total	34 019 (74 999)	Mid & Rear	379 (55)	SAE 2:1 Capacity with Tailgate	21 (28)	EXTRA WHEELSET	
LADEN						26.5 R 25	672 (1 482)
Front	20 770 (45 790)						
Middle	23 481 (51 767)			Rated Payload	33 500 kg		
Rear	23 268 (51 297)				(73 855 lb)		
Total	67 519 (148 854)						

* All Groundpressures calculated with Michelin XADN+ Tyre

Dimensions

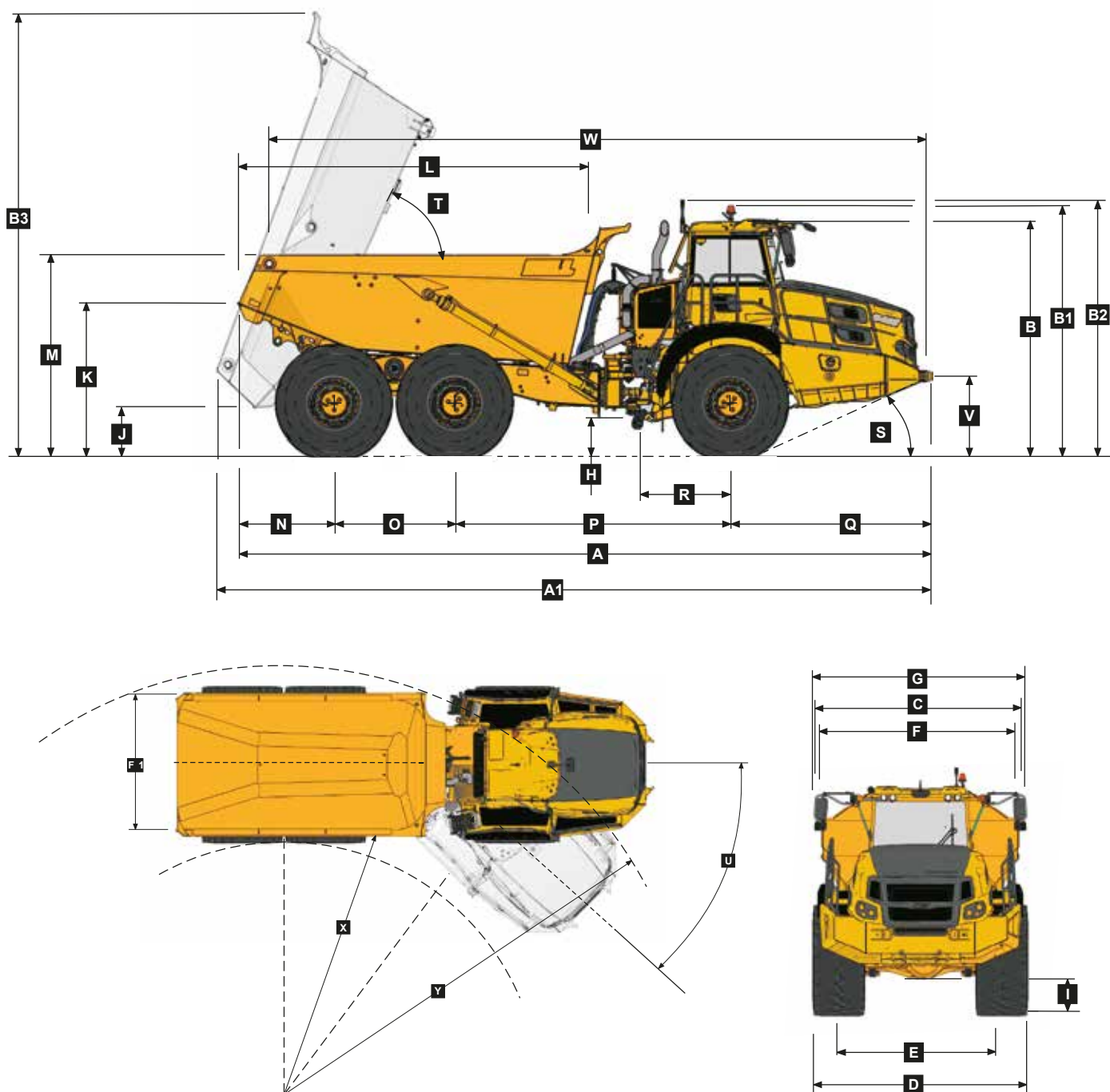

Machine Dimensions

A	Length - Transport Position with Tailgate	11 268 mm	(37 ft.)	K	Bin Lip Height - Transport Position	2 463 mm	(8 ft. 1 in.)
A	Length - Transport Position w/o Tailgate	11 188 mm	(36 ft. 8 in.)	L	Bin Length	5 709 mm	(18 ft. 9 in.)
A1	Length - Bin Fully Tipped	11 631 mm	(38 ft. 2 in.)	M	Load over Height	3 084 mm	(10 ft. 1 in.)
B	Height - Transport Position	3 752 mm	(12 ft. 4 in.)	N	Rear Axle Centre to Bin Rear	1 545 mm	(5 ft.)
B1	Height - Rotating Beacon	3 988 mm	(13 ft. 1 in.)	O	Mid Axle Centre to Rear Axle Centre	1 950 mm	(6 ft. 5 in.)
B2	Height - Load Light	4 076 mm	(13 ft. 4 in.)	P	Mid Axle Centre to Front Axle Centre	4 438 mm	(14 ft. 7 in.)
B3	Bin Height - Fully Tipped	7 213 mm	(23 ft. 8 in.)	Q	Front Axle Centre to Machine Front	3 255 mm	(10 ft. 8 in.)
C	Width over Mudguards	3 495 mm	(11 ft. 6 in.)	R	Front Axle Centre to Artic Centre	1 558 mm	(5 ft. 1 in.)
D	Width over Tyres - 26.5R25	3 438 mm	(11 ft. 3 in.)	S	Approach Angle	23 °	
E	Tyre Track Width - 26.5R25	2 768 mm	(9 ft. 1 in.)	T	Maximum Bin Tip Angle	70 °	
F	Width over Bin	3 112 mm	(10 ft. 3 in.)	U	Maximum Articulation Angle	42 °	
F1	Width over Tailgate	3 402 mm	(11 ft. 2 in.)	V	Front Tie Down Height	1 215 mm	(4 ft.)
G	Width over Mirrors - Operating Position	3 614 mm	(11 ft. 10 in.)	W	Machine Lifting Centres	10 655 mm	(34 ft. 11 in.)
H	Ground Clearance - Artic	493 mm	(19.41 in.)	X	Inner Turning Circle Radius - 26.5R25	4 891 mm	(16 ft.)
I	Ground Clearance - Front Axle	493 mm	(19.41 in.)	Y	Outer Turning Circle Radius - 26.5R25	9 211 mm	(30 ft. 3 in.)
J	Ground Clearance - Bin Fully Tipped	822 mm	(32.4 in.)				

Gradeability/Rimpull

1. Determine tractive resistance by finding intersection of vehicle mass line and grade line. NOTE: 2% typical rolling resistance is already assumed in chart and grade line.
2. From this intersection, move straight right across charts until line intersects rimpull curve.
3. Read down from this point to determine maximum speed attained at that tractive resistance.

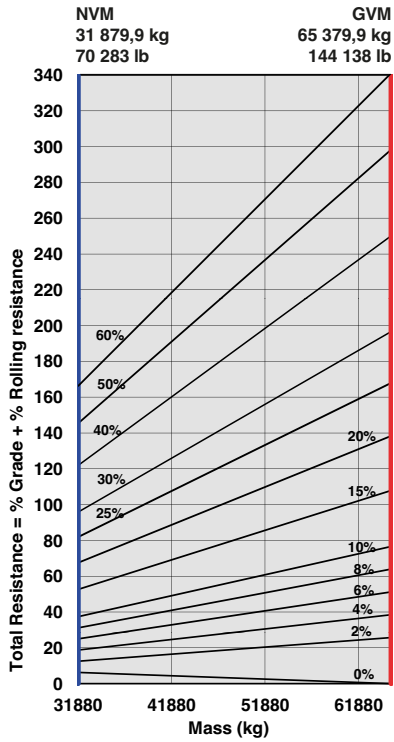

ADT, B35E 6X6 - Tractive Effort

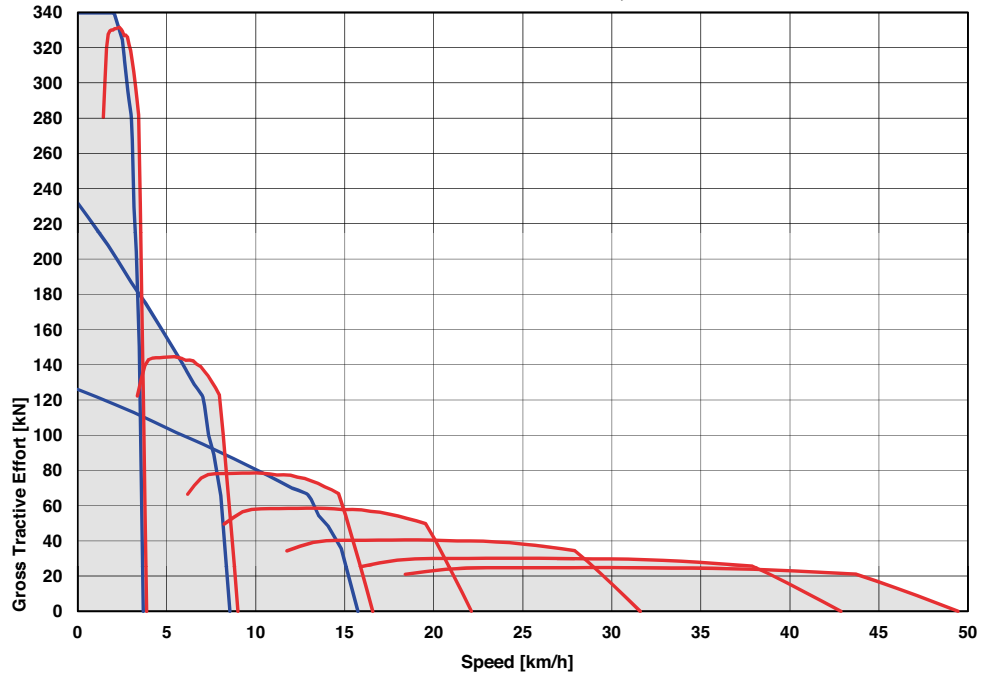

Retardation

1. Determine retardation force required by finding intersection of vehicle mass line.
2. From this intersection, move straight right across charts until line intersects the curve. NOTE: 2% typical rolling resistance is already assumed in chart.
3. Read down from this point to determine maximum speed.

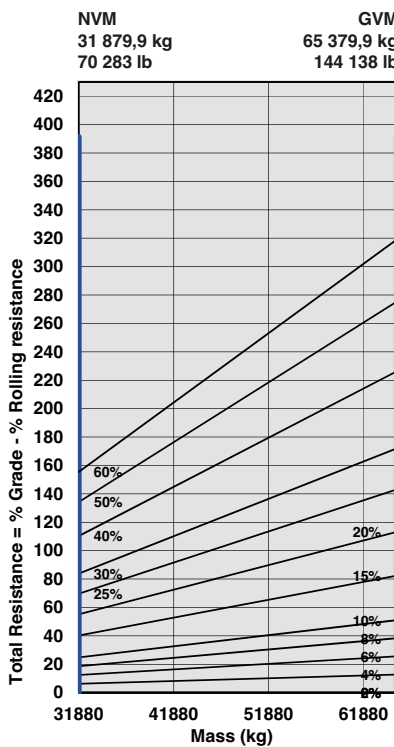

ADT, B35E 6X6 - Retardation

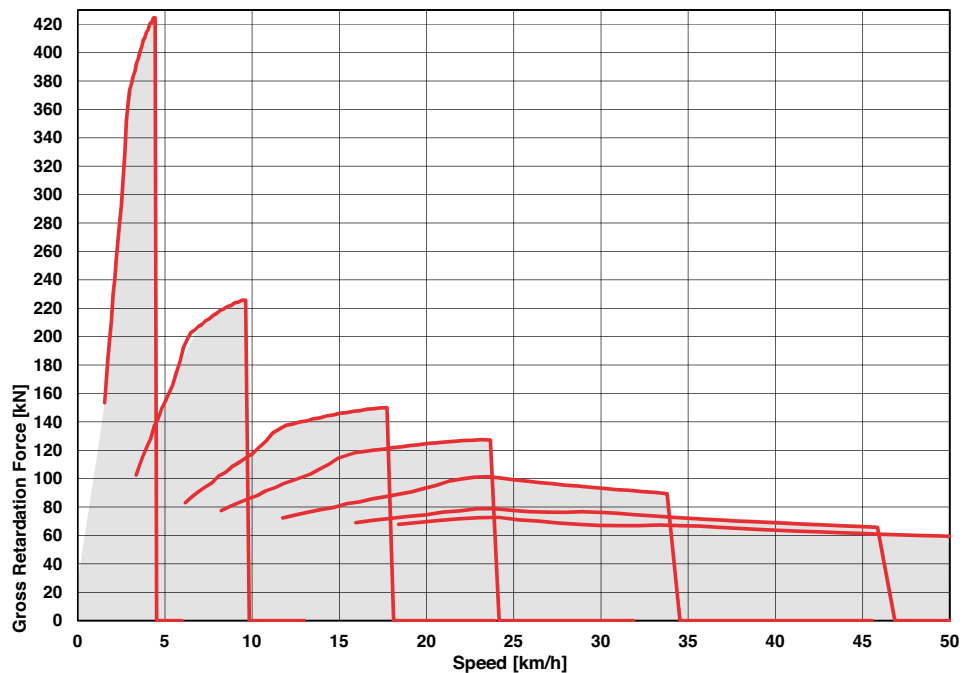

B40E Articulated Dump Truck

ENGINE

Manufacturer
Mercedes Benz (MTU)

Model
OM471LA (MTU 6R 1300)

Configuration
Inline 6, turbocharged and intercooled.

Gross Power
380 kW (510 hp) @ 1 700 rpm

Net Power
361 kW (484 hp) @ 1 700 rpm

Gross Torque
2 380 Nm (1 755 lbft) @ 1 300 rpm

Displacement
12,8 litres (781 cu.in)

Auxiliary Brake
Jacobs Engine Brake®

Fuel Tank Capacity
352 litres (93 US gal)

AdBlue® Tank Capacity
40 litres (11 US gal)

Certification
OM471LA (MTU 6R 1300) meets EU Stage V emissions regulations

TRANSMISSION

Manufacturer
Allison

Model
4700 ORS

Configuration
Fully automatic planetary transmission.

Layout
Engine mounted

Gear Layout
Constant meshing planetary gears, clutch operated

Gears
7 Forward, 1 Reverse

Clutch Type
Hydraulically operated multi-disc

Control Type
Electronic

Torque Control
Hydrodynamic with lock-up in all gears.

TRANSFER CASE

Manufacturer
Kessler

Series
W2400

Layout
Remote mounted

Gear Layout
Three in-line helical gears

Output Differential
Interaxle 29/71 proportional differential. Automatic inter-axle differential lock.

AXLES

Manufacturer
Bell

Model
30T

Differential
High input controlled traction differential with spiral bevel gears

Final Drive
Outboard heavy duty planetary on all axles.

BRAKING SYSTEM

Service Brake
Dual circuit, full hydraulic actuation wet disc brakes on front and middle axles. Wet brake oil is circulated through a filtration and cooling system.

Maximum brake force:
327 kN (73 513 lbf)

Park & Emergency
Spring applied, air released driveline mounted disc.

Maximum brake force:
218 kN (49 008 lbf)

Auxiliary Brake
Jacobs Engine Brake®. Automatic retardation through electronic activation of wet brake system.

Total Retardation Power
Continuous: 442 kW (593 hp)
Maximum: 854 kW (1 145 hp)

WHEELS

Type
Radial Earthmover

Tyre
29.5 R 25 (875/65 R 29 optional)

FRONT SUSPENSION

Semi-independent, leading A-frame supported by hydro-pneumatic suspension struts.

Option: Electronically controlled adaptive suspension with ride height adjustment.

REAR SUSPENSION

Pivoting walking beams with laminated rubber suspension blocks.

Option: Comfort Ride suspension walking beams, with two-stage sandwich block.

HYDRAULIC SYSTEM

Full load sensing system serving the prioritized steering, body tipping and brake functions. A ground-driven, load sensing emergency steering pump is integrated into the main system.

Pump Type
Variable displacement load sensing piston

Flow
330 L/min (87 gal/min)

Pressure
310 Bar (4 500 psi)

Filter
5 microns

STEERING SYSTEM

Double acting cylinders, with ground-driven emergency steering pump.

Lock to lock turns
5

Steering Angle
42°

DUMPING SYSTEM

Two double-acting, single stage, dump cylinders.

Raise Time
11 seconds

Lowering Time
6 seconds

Tipping Angle
70 deg standard, or any lower angle programmable

PNEUMATIC SYSTEM

Air drier with heater and integral unloader valve, serving park brake and auxiliary functions.

System Pressure
8,1 Bar (117 psi)

ELECTRICAL SYSTEM

Voltage
24 V

Battery Type
Two AGM (Absorption Glass Mat) type.

Battery Capacity
2 X 75 Ah

Alternator Rating
28V 80A

MAX. VEHICLE SPEED

1st	4 km/h	2,5 mph
2nd	9 km/h	6 mph
3rd	17 km/h	11 mph
4th	23 km/h	14 mph
5th	33 km/h	21 mph
6th	44 km/h	27,3 mph
7th	51 km/h	32 mph
R	7 km/h	4 mph

CAB

ROPS/FOPS certified 72 dBA internal sound level measured according to ISO 6396.

Load Capacity & Ground Pressure

OPERATING WEIGHTS		GROUND PRESSURE*		LOAD CAPACITY		OPTION WEIGHTS	
UNLADEN	kg (lb)	LADEN		BODY	m ³ (yd ³)		kg (lb)
Front	16 816 (37 072)	(No sinkage/Total Contact Area Method)		Struck Capacity	19 (25)	Bin liner	1 369 (3 018)
Middle	8 997 (19 834)	29.5 R 25	kPa (Psi)	SAE 2:1 Capacity	24 (31)	Tailgate	984 (2 169)
Rear	8 784 (19 365)	Front	310 (45)	SAE 1:1 Capacity	28,5 (37)	875/65 R29	
Total	34 596 (76 271)	Mid & Rear	341 (50)	SAE 2:1 Capacity with Tailgate	24,5 (32)	(per vehicle) Add	1 182 (2 606)
LADEN						EXTRA WHEELSET	
Front	21 691 (47 820)	875/65 R29	kPa (Psi)			29.5 R 25	800 (1 764)
Middle	26 059 (57 450)	Front	293 (43)	Rated Payload	39 000 kg	875/65 R29	1 024 (2 258)
Rear	25 846 (56 981)	Mid & Rear	329 (48)		(85 980 lb)		
Total	73 596 (162 251)						

* 29.5R25 Groundpressures calculated with Michelin XADN+ Tyre. 875/65R29 Groundpressures calculated with Michelin XAD65-1 Tyre.

B40E

Dimensions

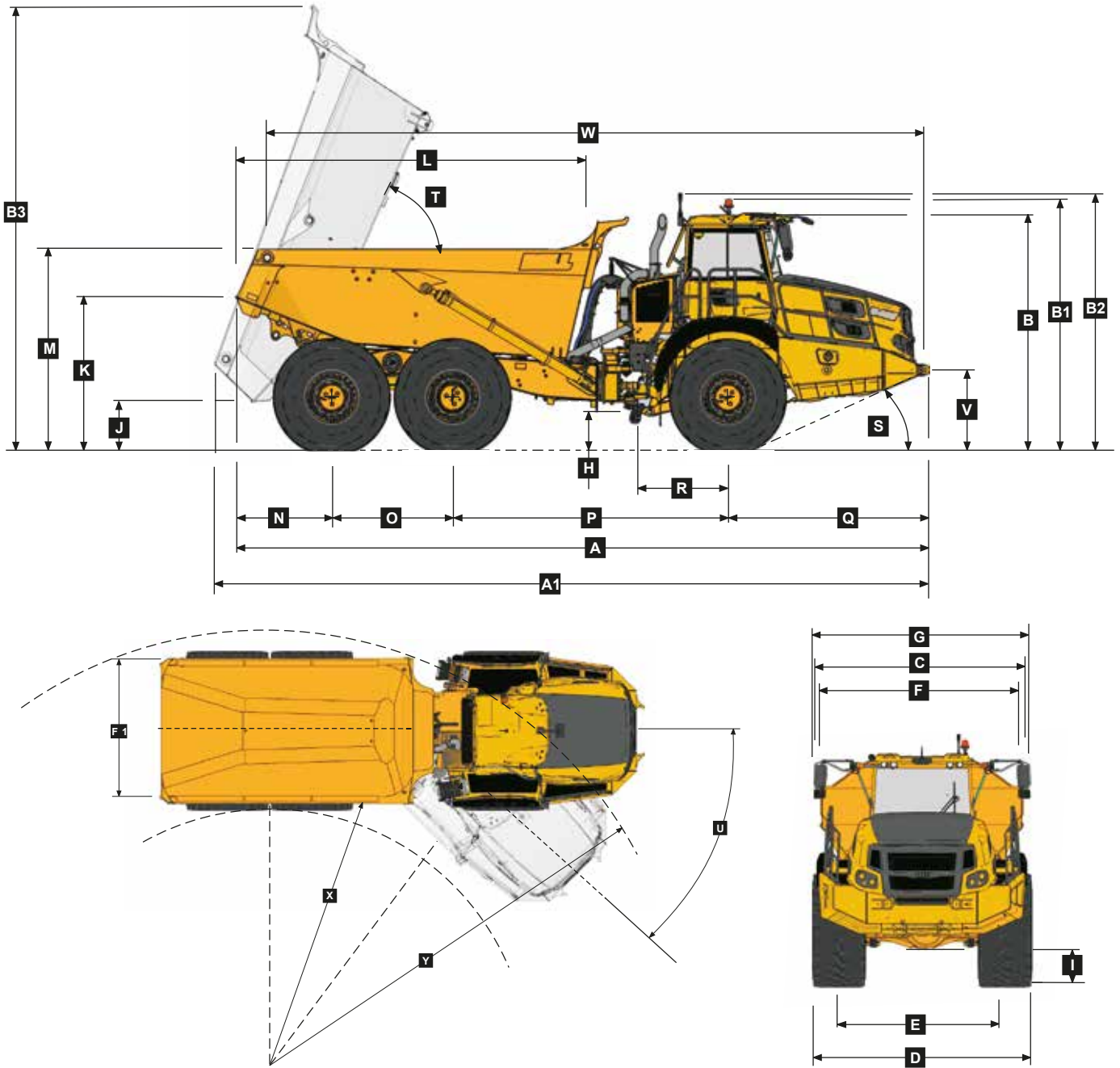

Machine Dimensions

A	Length - Transport Position with Tailgate	11 197 mm (36 ft. 9 in.)	K	Bin Lip Height - Transport Position	2 519 mm (8 ft. 3 in.)
A	Length - Transport Position w/o Tailgate	11 186 mm (36 ft. 8 in.)	L	Bin Length	5 742 mm (18 ft. 10 in.)
A1	Length - Bin Fully Tipped	11 742 mm (38 ft. 6 in.)	M	Load over Height	3 271 mm (10 ft. 9 in.)
B	Height - Transport Position	3 804 mm (12 ft. 6 in.)	N	Rear Axle Centre to Bin Rear	1 543 mm (5 ft.)
B1	Height - Rotating Beacon	4 040 mm (13 ft. 3 in.)	O	Mid Axle Centre to Rear Axle Centre	1 950 mm (6 ft. 5 in.)
B2	Height - Load Light	4 129 mm (13 ft. 7 in.)	P	Mid Axle Centre to Front Axle Centre	4 438 mm (14 ft. 7 in.)
B3	Bin Height - Fully Tipped	7 316 mm (24 ft.)	Q	Front Axle Centre to Machine Front	3 255 mm (10 ft. 8 in.)
C	Width over Mudguards	3 495 mm (11 ft. 6 in.)	R	Front Axle Centre to Artic Centre	1 558 mm (5 ft. 1 in.)
D	Width over Tyres - 875/65 R29	3 656 mm (12 ft.)	S	Approach Angle	24°
D	Width over Tyres - 29.5R25	3 487 mm (11 ft. 5 in.)	T	Maximum Bin Tip Angle	70°
E	Tyre Track Width - 875/65 R29	2 773 mm (9 ft. 1 in.)	U	Maximum Articulation Angle	42°
E	Tyre Track Width - 29.5R25	2 725 mm (8 ft. 11 in.)	V	Front Tie Down Height	1 265 mm (4 ft. 2 in.)
F	Width over Bin	3 372 mm (11 ft.)	W	Machine Lifting Centres	10 594 mm (34 ft. 9 in.)
F1	Width over Tailgate	3 662 mm (12 ft.)	X	Inner Turning Circle Radius - 875/65 R29	4 782 mm (15 ft. 8 in.)
G	Width over Mirrors - Operating Position	3 614 mm (11 ft. 10 in.)	X	Inner Turning Circle Radius - 29.5R25	4 866 mm (16 ft.)
H	Ground Clearance - Artic	545 mm (21.46 in.)	Y	Outer Turning Circle Radius - 875/65 R29	9 320 mm (30 ft. 7 in.)
I	Ground Clearance - Front Axle	545 mm (21.46 in.)	Y	Outer Turning Circle Radius - 29.5R25	9 235 mm (30 ft. 4 in.)
J	Ground Clearance - Bin Fully Tipped	876 mm (34.5 in.)			

Gradeability/Rimpull

1. Determine tractive resistance by finding intersection of vehicle mass line and grade line. NOTE: 2% typical rolling resistance is already assumed in chart and grade line.
2. From this intersection, move straight right across charts until line intersects rimpull curve.
3. Read down from this point to determine maximum speed attained at that tractive resistance.

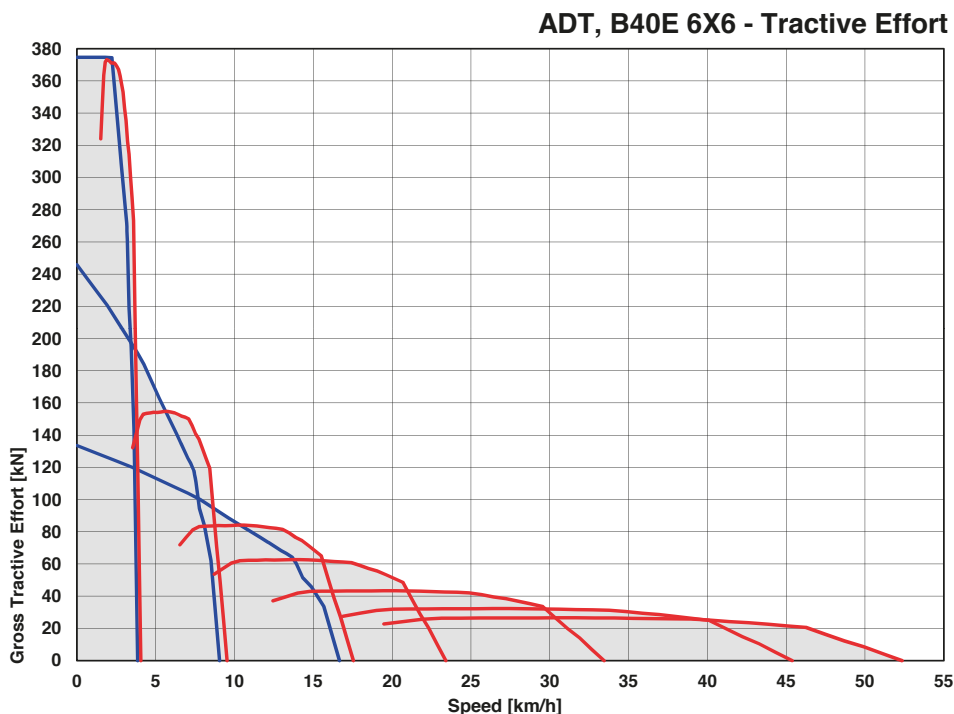
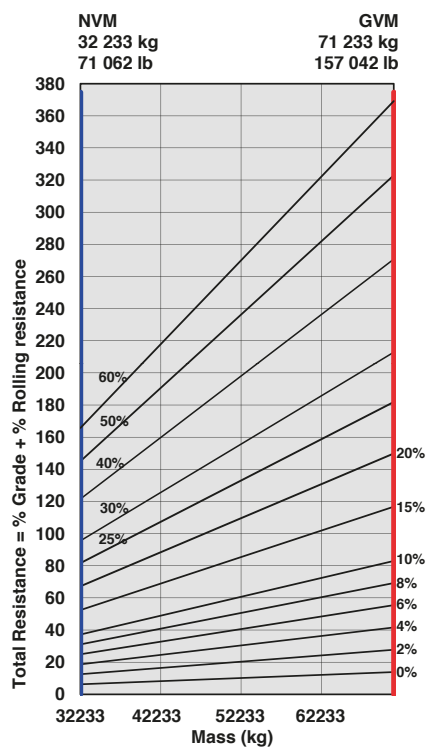

Retardation

1. Determine retardation force required by finding intersection of vehicle mass line.
2. From this intersection, move straight right across charts until line intersects the curve. NOTE: 2% typical rolling resistance is already assumed in chart.
3. Read down from this point to determine maximum speed.

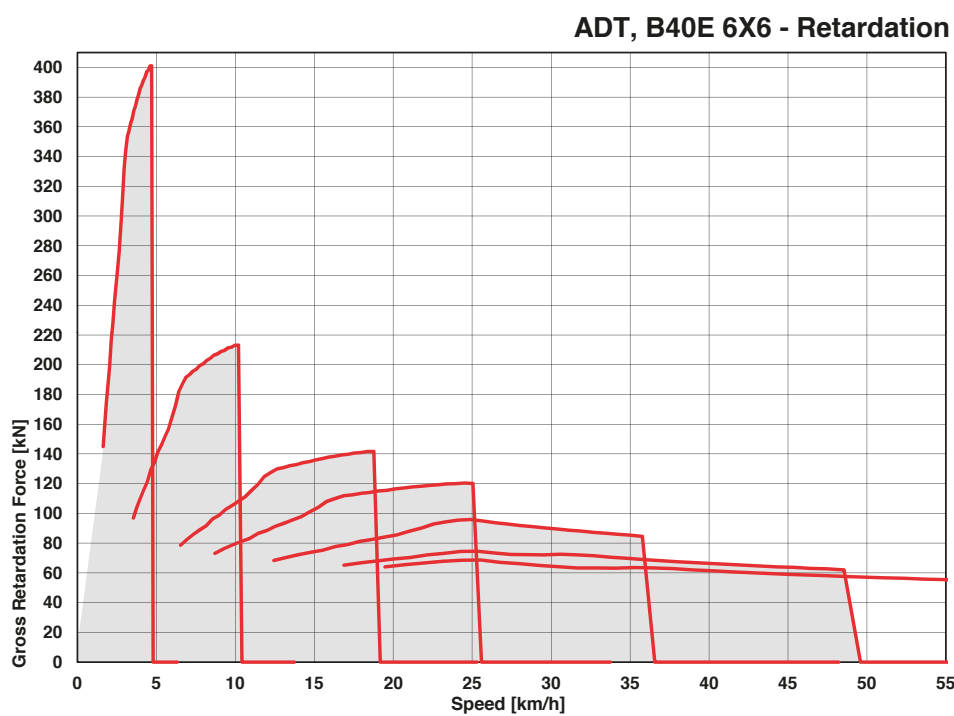
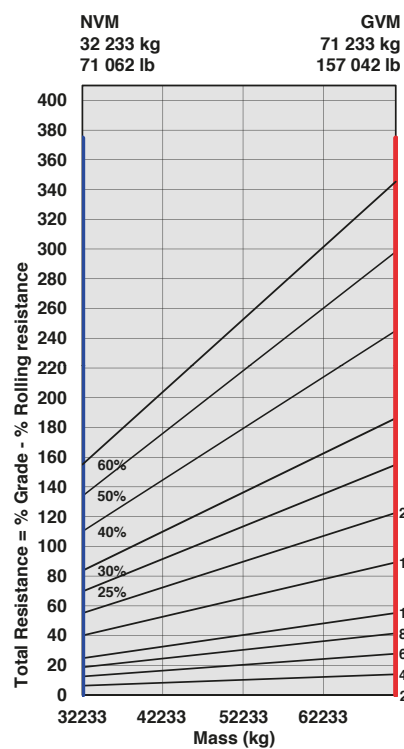

B45E Articulated Dump Truck

ENGINE

Manufacturer
Mercedes Benz (MTU)

Model
OM471LA (MTU 6R 1300)

Configuration
Inline 6, turbocharged and intercooled.

Gross Power
390 kW (523 hp) @ 1 700 rpm

Net Power
371 kW (498 hp) @ 1 700 rpm

Gross Torque
2 460 Nm (1 814 lbf) @ 1 300 rpm

Displacement
12,8 litres (781 cu.in)

Auxiliary Brake
Jacobs Engine Brake®

Fuel Tank Capacity
352 litres (93 US gal)

AdBlue® Tank Capacity
40 litres (11 US gal)

Certification
OM471LA (MTU 6R 1300) meets EU Stage V emissions regulations

TRANSMISSION

Manufacturer
Allison

Model
4700 ORS

Configuration
Fully automatic planetary transmission.

Layout
Engine mounted

Gear Layout
Constant meshing planetary gears, clutch operated

Gears
7 Forward, 1 Reverse

Clutch Type
Hydraulically operated multi-disc

Control Type
Electronic

Torque Control
Hydrodynamic with lock-up in all gears.

TRANSFER CASE

Manufacturer
Kessler

Model
W2400

Layout
Remote mounted

Gear Layout
Three in-line helical gears

Output Differential
Interaxle 29/71 proportional differential. Automatic inter-axle differential lock.

AXLES

Manufacturer
Bell

Model
30T

Differential
High input controlled traction differential with spiral bevel gears

Final Drive
Outboard heavy duty planetary on all axles.

BRAKING SYSTEM

Service Brake
Dual circuit, full hydraulic actuation wet disc brakes on front and middle axles. Wet brake oil is circulated through a filtration and cooling system.

Maximum brake force:
327 kN (73 513 lbf)

Park & Emergency
Spring applied, air released driveline mounted disc.

Maximum brake force:
218 kN (49 008 lbf)

Auxiliary Brake
Jacobs Engine Brake®. Automatic retardation through electronic activation of wet brake system.

Total Retardation Power
Continuous: 442 kW (593 hp)
Maximum: 854 kW (1 145 hp)

WHEELS

Type
Radial Earthmover

Tyre
29.5 R 25 (875/65 R 29 optional)

FRONT SUSPENSION

Semi-independent, leading A-frame supported by hydro-pneumatic suspension struts.

Option: Electronically controlled adaptive suspension with ride height adjustment.

REAR SUSPENSION

Pivoting walking beams with laminated rubber suspension blocks.

Option: Comfort Ride suspension walking beams, with two-stage sandwich block.

HYDRAULIC SYSTEM

Full load sensing system serving the prioritized steering, body tipping and brake functions. A ground-driven, load sensing emergency steering pump is integrated into the main system.

Pump Type
Variable displacement load sensing piston

Flow
330 L/min (87 gal/min)

Pressure
310 Bar (4 500 psi)

Filter
5 microns

STEERING SYSTEM

Double acting cylinders, with ground-driven emergency steering pump.

Lock to lock turns
5

Steering Angle
42°

DUMPING SYSTEM

Two double-acting, single stage, dump cylinders.

Raise Time
11 seconds

Lowering Time
6 seconds

Tipping Angle
70 deg standard, or any lower angle programmable

PNEUMATIC SYSTEM

Air drier with heater and integral unloader valve, serving park brake and auxiliary functions.

System Pressure
8,1 Bar (117 psi)

ELECTRICAL SYSTEM

Voltage
24 V

Battery Type
Two AGM (Absorption Glass Mat) type.

Battery Capacity
2 X 75 Ah

Alternator Rating
28V 80A

MAX. VEHICLE SPEED

1st	4 km/h	2,5 mph
2nd	9 km/h	6 mph
3rd	17 km/h	11 mph
4th	23 km/h	14 mph
5th	33 km/h	21 mph
6th	44 km/h	27,3 mph
7th	51 km/h	32 mph
R	7 km/h	4 mph

CAB

ROPS/FOPS certified 72 dBA internal sound level measured according to ISO 6396.

Load Capacity & Ground Pressure

OPERATING WEIGHTS		GROUND PRESSURE*		LOAD CAPACITY		OPTION WEIGHTS	
UNLADEN	kg (lb)	LADEN		BODY	m ³ (yd ³)	kg (lb)	
Front	17 614 (38 832)	(No sinkage/Total Contact Area Method)		Struck Capacity	19,5 (25,5)	Bin liner	1 404 (3 095)
Middle	9 177 (20 232)	29.5 R 25	kPa (Psi)	SAE 2:1 Capacity	25 (33)	Tailgate	1 013 (2 233)
Rear	8 688 (19 154)	Front	321 (47)	SAE 1:1 Capacity	29,5 (38)	875/65 R29	
Total	35 479 (78 217)	Mid & Rear	370 (54)	SAE 2:1 Capacity with Tailgate	26 (34)	(per vehicle) Add	1 182 (2 606)
LADEN						EXTRA WHEELSET	
Front	22 739 (50 131)	875/65 R29	kPa (Psi)			29.5 R 25	800 (1 764)
Middle	27 115 (59 778)	Front	294 (43)	Rated Payload	41 000 kg	875/65 R29	1 024 (2 258)
Rear	26 626 (58 700)	Mid & Rear	331 (48)		(90 390 lb)		
Total	76 479 (168 607)						

* 29.5R25 Groundpressures calculated with Michelin XADN+ Tyre. 875/65R29 Groundpressures calculated with Michelin XAD65-1 Tyre.

Dimensions

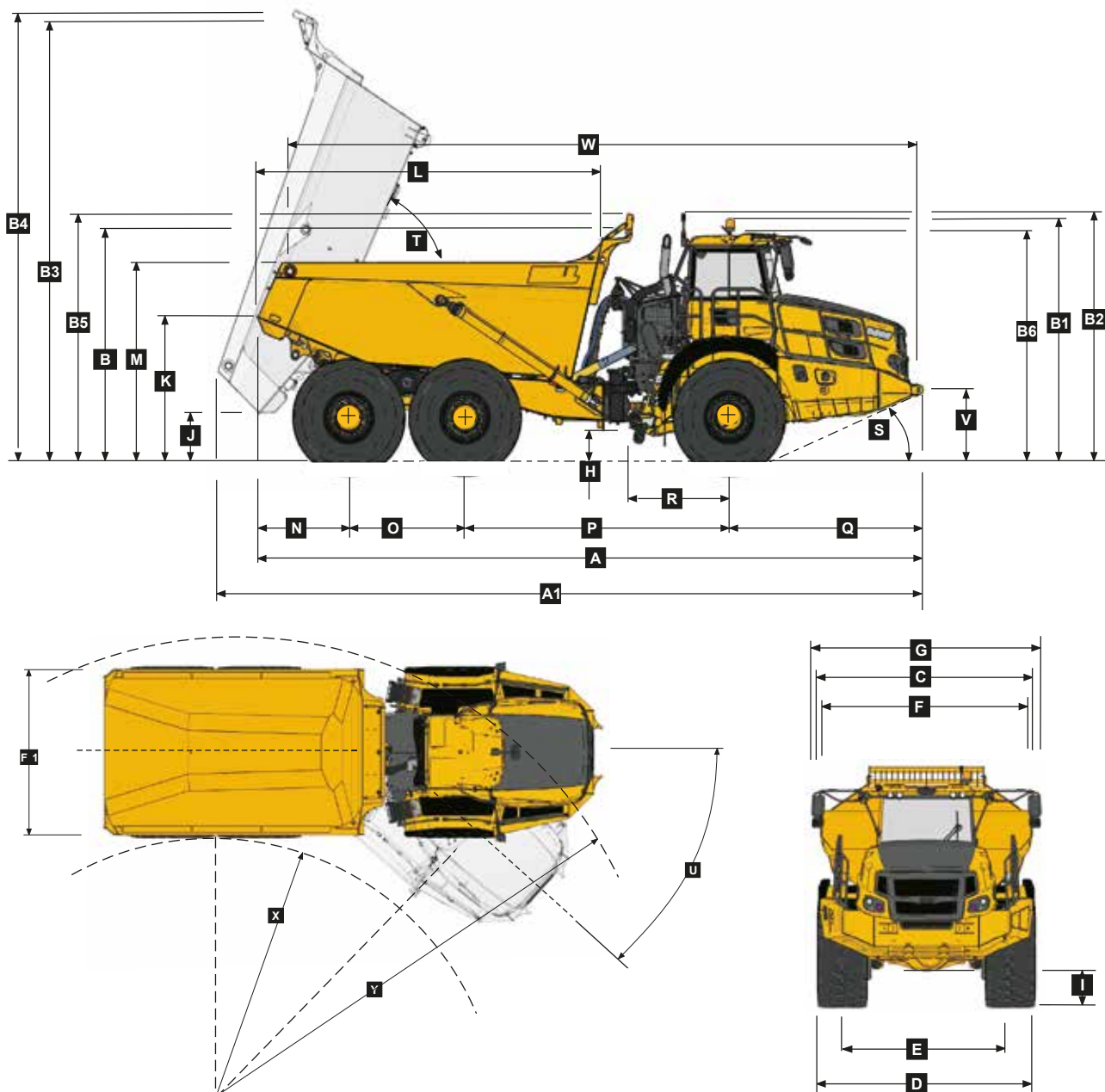

Machine Dimensions

A	Length - Transport Position with Tailgate	11 184 mm	(36 ft. 8 in.)	I	Ground Clearance - Front Axle	543 mm	(21.34 in.)
A	Length - Transport Position w/o Tailgate	11 184 mm	(36 ft. 8 in.)	J	Ground Clearance - Bin Fully Tipped	880 mm	(34.65 in.)
A1	Length - Bin Fully Tipped	11 778 mm	(38 ft. 8 in.)	K	Bin Lip Height - Transport Position	2 521 mm	(8 ft. 3 in.)
B	Height - Transport Position w/o Rock Guard	3 802 mm	(12 ft. 6 in.)	L	Bin Length	5 753 mm	(18 ft. 10 in.)
B	Height - Transport Position with Rock Guard	3 844 mm	(12 ft. 7 in.)	M	Load over Height	3 316 mm	(10 ft. 11 in.)
B1	Height - Rotating Beacon	4 038 mm	(13 ft. 3 in.)	N	Rear Axle Centre to Bin Rear	1 540 mm	(5 ft.)
B2	Height - Load Light	4 127 mm	(13 ft. 6 in.)	O	Mid Axle Centre to Rear Axle Centre	1 950 mm	(6 ft. 5 in.)
B3	Bin Height - Fully Tipped w/o Rock Guard	7 340 mm	(24 ft. 1 in.)	P	Mid Axle Centre to Front Axle Centre	4 438 mm	(14 ft. 7 in.)
B4	Bin Height - Fully Tipped with Rock Guard	7 448 mm	(24 ft. 5 in.)	Q	Front Axle Centre to Machine Front	3 256 mm	(10 ft. 8 in.)
B5	Height - Rock Guard Operating Position	4 123 mm	(13 ft. 6 in.)	R	Front Axle Centre to Artic Centre	1 558 mm	(5 ft. 1 in.)
B6	Height - Cab	3 802 mm	(12 ft. 6 in.)	S	Approach Angle	24 °	
C	Width over Mudguards	3 495 mm	(11 ft. 6 in.)	T	Maximum Bin Tip Angle	70 °	
D	Width over Tyres - 875/65 R29	3 656 mm	(12 ft.)	U	Maximum Articulation Angle	42 °	
D	Width over Tyres - 29.5R25	3 487 mm	(11 ft. 5 in.)	V	Front Tie Down Height	1 262 mm	(4 ft. 2 in.)
E	Tyre Track Width - 875/65 R29	2 773 mm	(9 ft. 1 in.)	W	Machine Lifting Centres	10 569 mm	(34 ft. 8 in.)
E	Tyre Track Width - 29.5R25	2 725 mm	(8 ft. 11 in.)	X	Inner Turning Circle Radius - 875/65 R29	4 782 mm	(15 ft. 8 in.)
F	Width over Bin	3 448 mm	(11 ft. 4 in.)	X	Inner Turning Circle Radius - 29.5R25	4 866 mm	(16 ft.)
F1	Width over Tailgate	3 738 mm	(12 ft. 3 in.)	Y	Outer Turning Circle Radius - 875/65 R29	9 320 mm	(30 ft. 7 in.)
G	Width over Mirrors - Operating Position	4 027 mm	(13 ft. 3 in.)	Y	Outer Turning Circle Radius - 29.5R25	9 235 mm	(30 ft. 4 in.)
H	Ground Clearance - Artic	545 mm	(21.46 in.)				

Gradeability/Rimpull

1. Determine tractive resistance by finding intersection of vehicle mass line and grade line. NOTE: 2% typical rolling resistance is already assumed in chart and grade line.
2. From this intersection, move straight right across charts until line intersects rimpull curve.
3. Read down from this point to determine maximum speed attained at that tractive resistance.

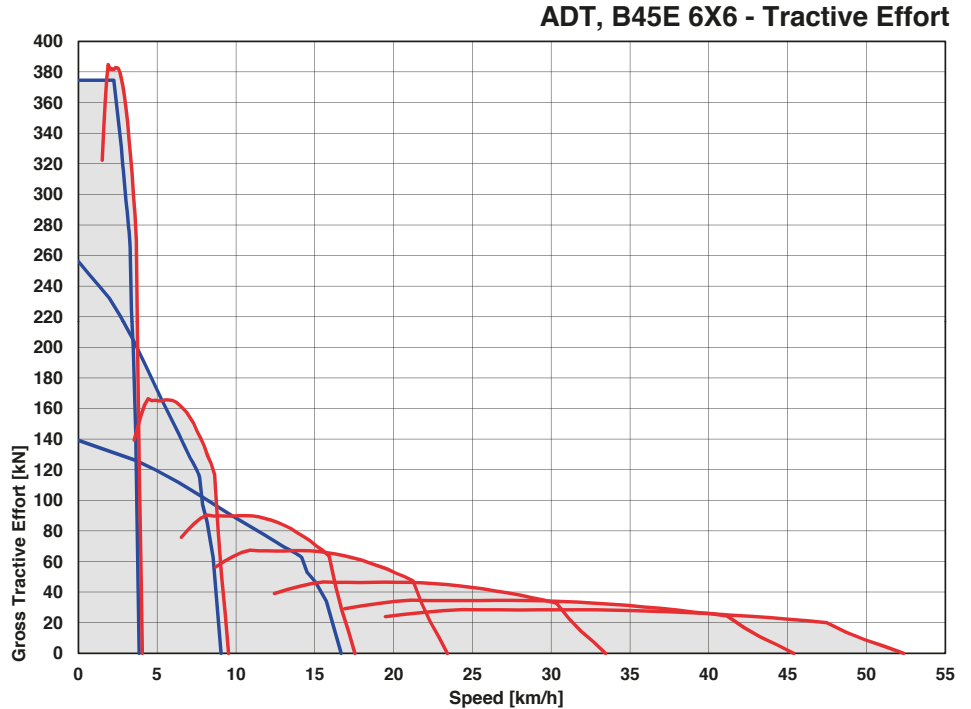
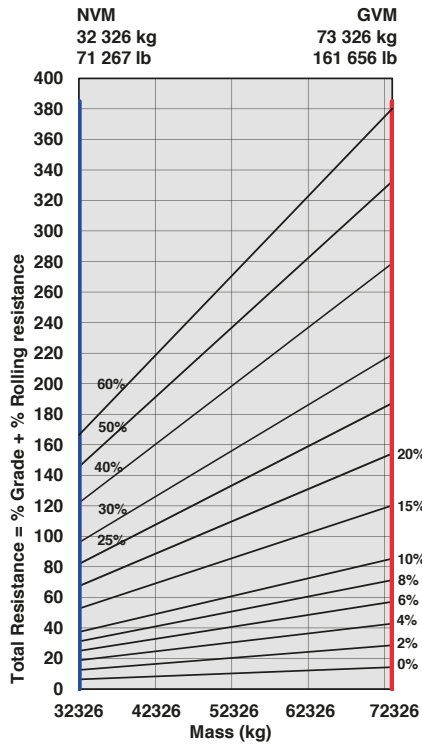

Retardation

1. Determine retardation force required by finding intersection of vehicle mass line.
2. From this intersection, move straight right across charts until line intersects the curve. NOTE: 2% typical rolling resistance is already assumed in chart.
3. Read down from this point to determine maximum speed.

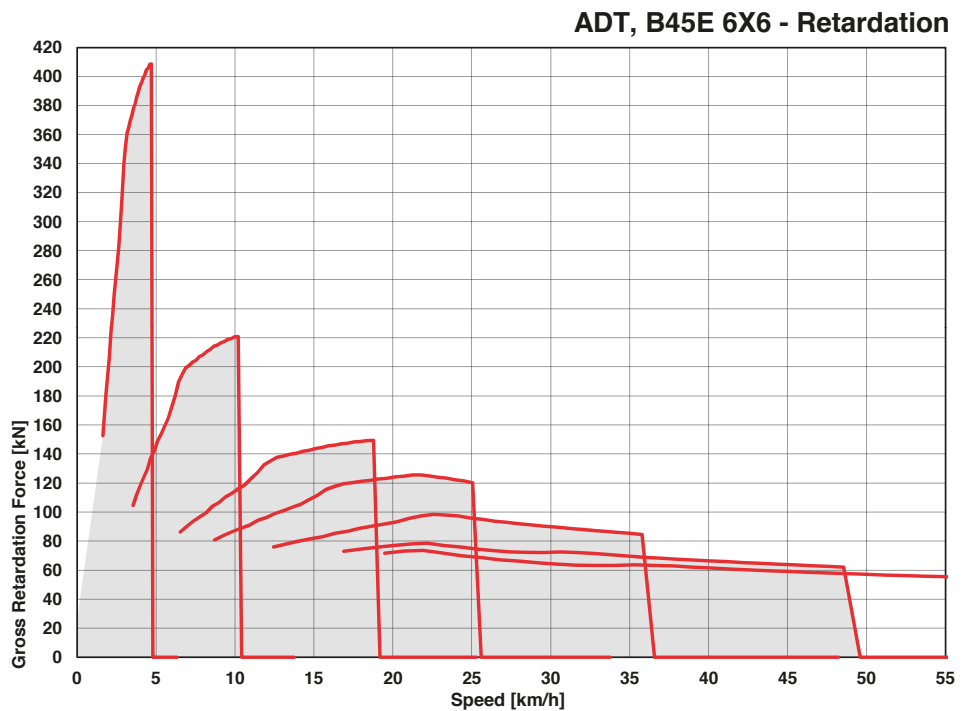
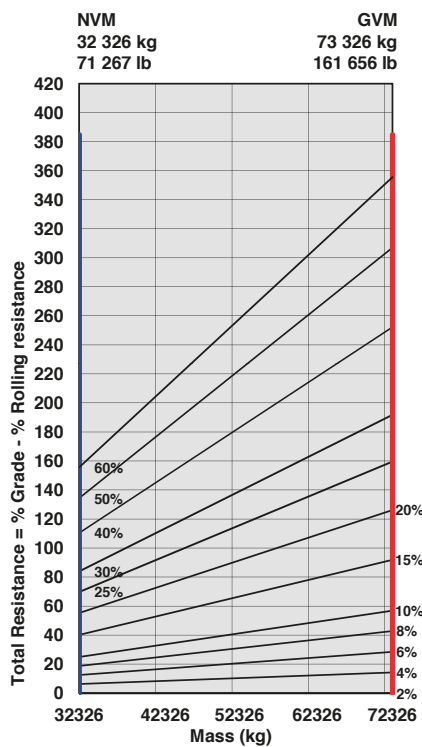

B50E Articulated Dump Truck

<p>ENGINE</p> <p>Manufacturer Mercedes Benz (MTU)</p> <p>Model OM473LA (MTU 6R 1500)</p> <p>Configuration Inline 6, turbocharged and intercooled.</p> <p>Gross Power 430 kW (577 hp) @ 1 700 rpm</p> <p>Net Power 408 kW (547 hp) @ 1 700 rpm</p> <p>Gross Torque 2 750 Nm (2 028 lbft) @ 1 300 rpm</p> <p>Displacement 15,6 litres (952 cu.in)</p> <p>Auxiliary Brake Jacobs Engine Brake®</p> <p>Fuel Tank Capacity 494 litres (130 US gal)</p> <p>AdBlue® Tank Capacity 40 litres (11 US gal)</p> <p>Certification OM473LA (MTU 6R 1500) meets EU Stage V emissions regulations</p>	<p>Torque Control Hydrodynamic with lock-up in all gears.</p> <p>TRANSFER CASE</p> <p>Manufacturer Kessler</p> <p>Series W2400</p> <p>Layout Remote mounted</p> <p>Gear Layout Three in-line helical gears</p> <p>Output Differential Interaxle 29/71 proportional differential. Automatic inter-axle differential lock.</p> <p>AXLES</p> <p>Manufacturer Bell</p> <p>Model 30T</p> <p>Differential High input controlled traction differential with spiral bevel gears</p> <p>Final Drive Outboard heavy duty planetary on all axles.</p> <p>BRAKING SYSTEM</p> <p>Service Brake Dual circuit, full hydraulic actuation wet disc brakes on front, middle and rear axles. Wet brake oil is circulated through a filtration and cooling system.</p> <p>Maximum brake force: 488 kN (109 707 lbf)</p> <p>Park & Emergency Spring applied, air released driveline mounted disc.</p> <p>Maximum brake force: 215,5 kN (48 446 lbf)</p> <p>Auxiliary Brake Jacobs Engine Brake®. Automatic retardation through electronic activation of wet brake system.</p>	<p>Total Retardation Power Continuous: 546 kW (732 hp) Maximum: 963 kW (1 291 hp)</p> <p>WHEELS</p> <p>Type Radial Earthmover</p> <p>Tyre 875/65 R 29 (29.5 R 25 optional)</p> <p>FRONT SUSPENSION Semi-independent, leading A-frame supported by hydro-pneumatic suspension struts. Suspension is electronically controlled adaptive suspension with ride height adjustment.</p> <p>REAR SUSPENSION Pivoting walking beams with laminated rubber suspension blocks. Option: Comfort Ride suspension walking beams, with two-stage sandwich block.</p> <p>HYDRAULIC SYSTEM Full load sensing system serving the prioritized steering, body tipping, suspension and brake functions. A ground-driven, load sensing emergency steering pump is integrated into the main system.</p> <p>Pump Type Variable displacement load sensing piston</p> <p>Flow 330 L/min (87 gal/min)</p> <p>Pressure 310 Bar (4 500 psi)</p> <p>Filter 5 microns</p> <p>STEERING SYSTEM Double acting cylinders, with ground-driven emergency steering pump.</p> <p>Lock to lock turns 4,9</p> <p>Steering Angle 42°</p>	<p>DUMPING SYSTEM</p> <p>Two double-acting, single stage, dump cylinders.</p> <p>Raise Time 11,5 seconds</p> <p>Lowering Time 6 seconds</p> <p>Tipping Angle 70 deg standard, or any lower angle programmable</p> <p>PNEUMATIC SYSTEM Air drier with heater and integral unloader valve, serving park brake and auxiliary functions.</p> <p>System Pressure 8,1 Bar (117 psi)</p> <p>ELECTRICAL SYSTEM</p> <p>Voltage 24 V</p> <p>Battery Type Two AGM (Absorption Glass Mat) type.</p> <p>Battery Capacity 2 X 75 Ah</p> <p>Alternator Rating 28V 80A</p> <p>MAX. VEHICLE SPEED</p> <table border="1"> <tr><td>1st</td><td>4 km/h</td><td>2,5 mph</td></tr> <tr><td>2nd</td><td>9 km/h</td><td>6 mph</td></tr> <tr><td>3rd</td><td>17 km/h</td><td>11 mph</td></tr> <tr><td>4th</td><td>23 km/h</td><td>14 mph</td></tr> <tr><td>5th</td><td>33 km/h</td><td>21 mph</td></tr> <tr><td>6th</td><td>44 km/h</td><td>27,3 mph</td></tr> <tr><td>7th</td><td>51 km/h</td><td>32 mph</td></tr> <tr><td>R</td><td>7 km/h</td><td>4 mph</td></tr> </table> <p>CAB ROPS/FOPS certified 74 dBA internal sound level measured according to ISO 6396.</p>	1st	4 km/h	2,5 mph	2nd	9 km/h	6 mph	3rd	17 km/h	11 mph	4th	23 km/h	14 mph	5th	33 km/h	21 mph	6th	44 km/h	27,3 mph	7th	51 km/h	32 mph	R	7 km/h	4 mph
1st	4 km/h	2,5 mph																									
2nd	9 km/h	6 mph																									
3rd	17 km/h	11 mph																									
4th	23 km/h	14 mph																									
5th	33 km/h	21 mph																									
6th	44 km/h	27,3 mph																									
7th	51 km/h	32 mph																									
R	7 km/h	4 mph																									
<p>TRANSMISSION</p> <p>Manufacturer Allison</p> <p>Model 4800 ORS</p> <p>Configuration Fully automatic planetary transmission.</p> <p>Layout Engine mounted</p> <p>Gear Layout Constant meshing planetary gears, clutch operated</p> <p>Gears 7 Forward, 1 Reverse</p> <p>Clutch Type Hydraulically operated multi-disc</p> <p>Control Type Electronic</p>																											

Load Capacity & Ground Pressure

OPERATING WEIGHTS		GROUND PRESSURE*		LOAD CAPACITY		OPTION WEIGHTS	
UNLADEN	kg (lb)	LADEN		BODY	m ³ (yd ³)	kg (lb)	
Front	18 313 (40 373)	(No sinkage/Total Contact Area Method)		Struck Capacity	21,5 (28)	Bin liner	1 495 (3 296)
Middle	10 039 (22 132)	875/65 R29	kPa (Psi)	SAE 2:1 Capacity	27,5 (36)	Tailgate	1 117 (2 463)
Rear	9 934 (21 901)	Front	296 (43)	SAE 1:1 Capacity	33 (43)	29.5 R 25	
Total	38 287 (84 408)	Mid & Rear	366 (53)	SAE 2:1 Capacity with Tailgate	29 (38)	(per vehicle) Minus	1 182 (2 606)
LADEN						EXTRA WHEELSET	
Front	24 034 (52 986)	29.5 R 25	kPa (Psi)			29.5 R 25	800 (1 764)
Middle	29 879 (65 872)	Front	326 (47)	Rated Payload	45 400 kg	875/65 R29	1 024 (2 258)
Rear	29 774 (65 640)	Mid & Rear	395 (57)		(100 090 lb)		
Total	83 687 (184 498)						

* 29.5R25 Groundpressures calculated with Michelin XADN+ Tyre. 875/65 R29 Groundpressures calculated with Michelin XAD65-1 Tyre.

B50E

Dimensions

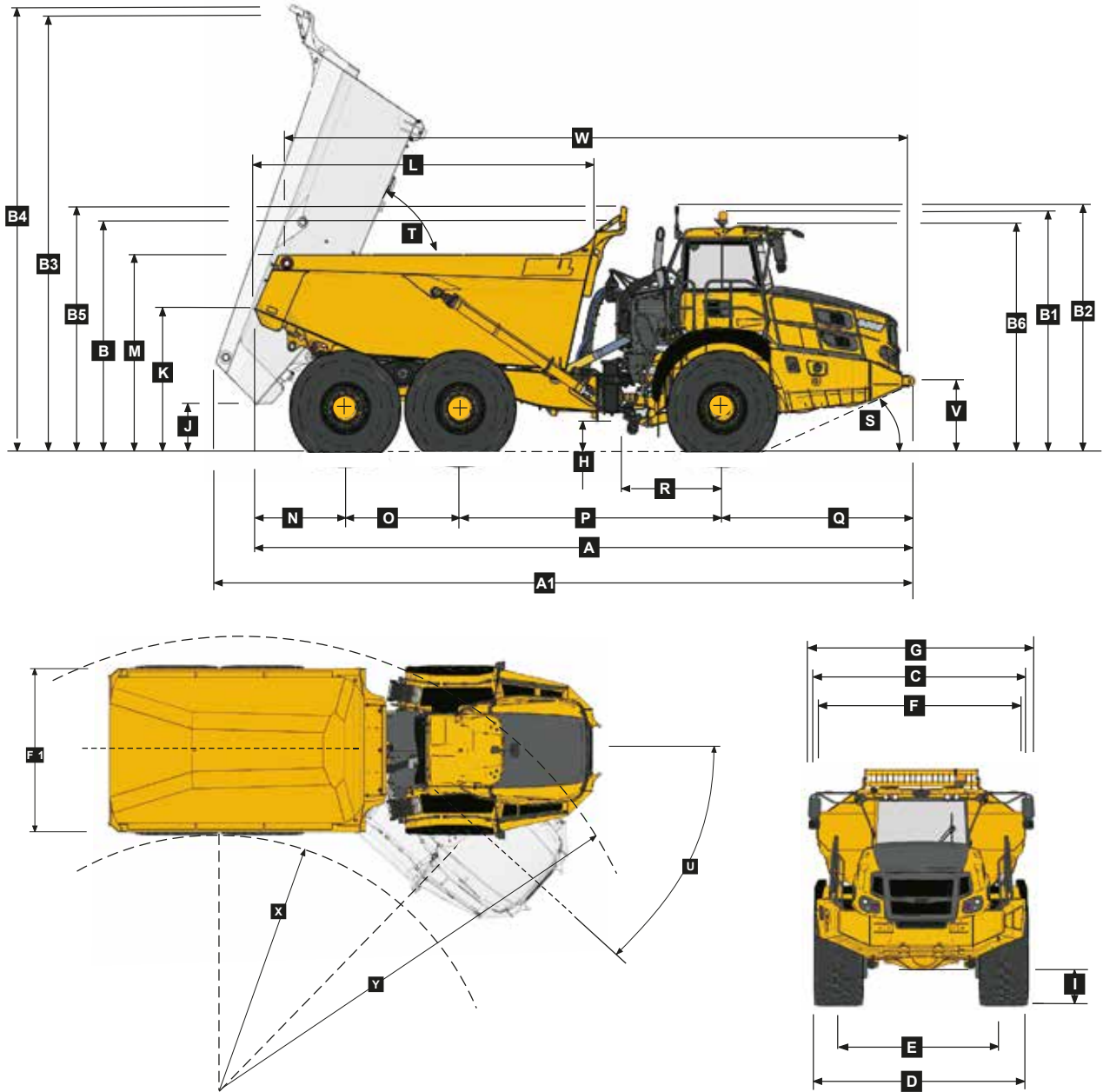

Machine Dimensions

A	Length - Transport Position with Tailgate	11 272 mm	(37 ft.)	I	Ground Clearance - Front Axle	555 mm	(21.85 in.)
A	Length - Transport Position w/o Tailgate	11 272 mm	(37 ft.)	J	Ground Clearance - Bin Fully Tipped	907 mm	(35.71 in.)
A1	Length - Bin Fully Tipped	11 916 mm	(39 ft. 1 in.)	K	Bin Lip Height - Transport Position	2 542 mm	(8 ft. 4 in.)
B	Height - Transport Position w/o Rock Guard	3 822 mm	(12 ft. 6 in.)	L	Bin Length	5 714 mm	(18 ft. 9 in.)
B	Height - Transport Position with Rock Guard	3 870 mm	(12 ft. 8 in.)	M	Load over Height	3 390 mm	(11 ft. 1 in.)
B1	Height - Rotating Beacon	4 050 mm	(13 ft. 3 in.)	N	Rear Axle Centre to Bin Rear	1 533 mm	(5 ft.)
B2	Height - Load Light	4 141 mm	(13 ft. 7 in.)	O	Mid Axle Centre to Rear Axle Centre	1 950 mm	(6 ft. 5 in.)
B3	Bin Height - Fully Tipped w/o Rock Guard	7 325 mm	(24 ft.)	P	Mid Axle Centre to Front Axle Centre	4 438 mm	(14 ft. 7 in.)
B4	Bin Height - Fully Tipped with Rock Guard	7 430 mm	(24 ft. 5 in.)	Q	Front Axle Centre to Machine Front	3 351 mm	(11 ft.)
B5	Height - Rock Guard Operating Position	4 148 mm	(13 ft. 7 in.)	R	Front Axle Centre to Artic Centre	1 558 mm	(5 ft. 1 in.)
B6	Height - Cab	3 813 mm	(12 ft. 6 in.)	S	Approach Angle	23°	
C	Width over Mudguards	3 790 mm	(12 ft. 5 in.)	T	Maximum Bin Tip Angle	70°	
D	Width over Tyres - 875/65 R29	3 832 mm	(12 ft. 7 in.)	U	Maximum Articulation Angle	42°	
D	Width over Tyres - 29.5R25	3 714 mm	(12 ft. 2 in.)	V	Front Tie Down Height	1 269 mm	(4 ft. 2 in.)
E	Tyre Track Width - 875/65 R29	2 949 mm	(9 ft. 8 in.)	W	Machine Lifting Centres	10 632 mm	(34 ft. 11 in.)
E	Tyre Track Width - 29.5R25	2 952 mm	(9 ft. 8 in.)	X	Inner Turning Circle Radius - 875/65 R29	4 694 mm	(15 ft. 5 in.)
F	Width over Bin	3 735 mm	(12 ft. 3 in.)	X	Inner Turning Circle Radius - 29.5R25	4 753 mm	(15 ft. 7 in.)
F1	Width over Tailgate	4 057 mm	(13 ft. 4 in.)	Y	Outer Turning Circle Radius - 875/65 R29	9 408 mm	(30 ft. 10 in.)
G	Width over Mirrors - Operating Position	4 027 mm	(13 ft. 3 in.)	Y	Outer Turning Circle Radius - 29.5R25	9 349 mm	(30 ft. 8 in.)
H	Ground Clearance - Artic	558 mm	(21.97 in.)				

Gradeability/Rimpull

1. Determine tractive resistance by finding intersection of vehicle mass line and grade line. NOTE: 2% typical rolling resistance is already assumed in chart and grade line.
2. From this intersection, move straight right across charts until line intersects rimpull curve.
3. Read down from this point to determine maximum speed attained at that tractive resistance.

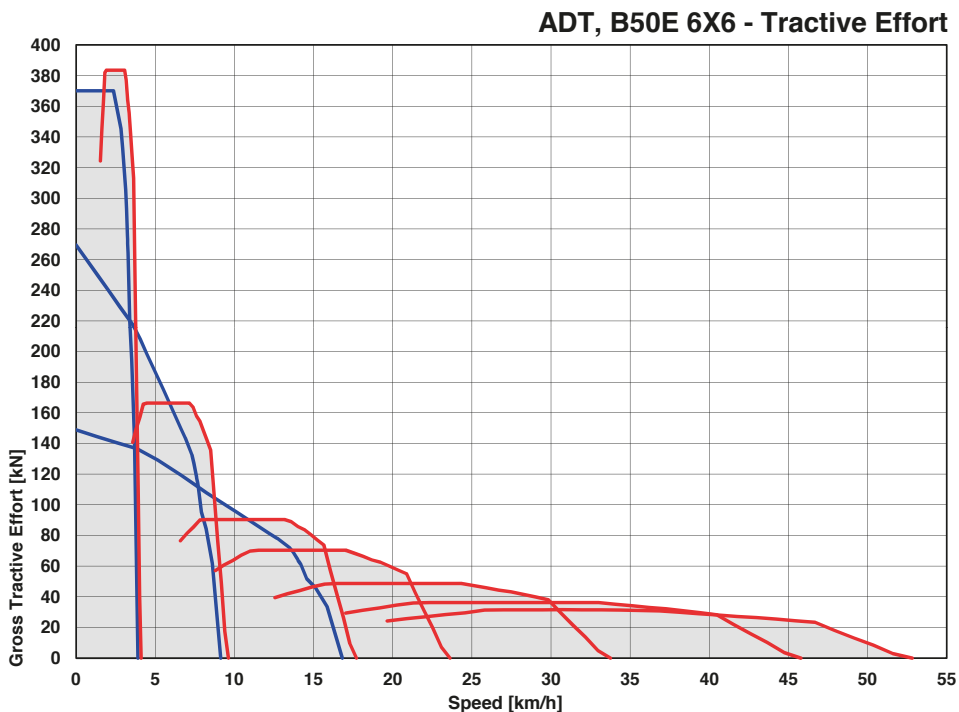
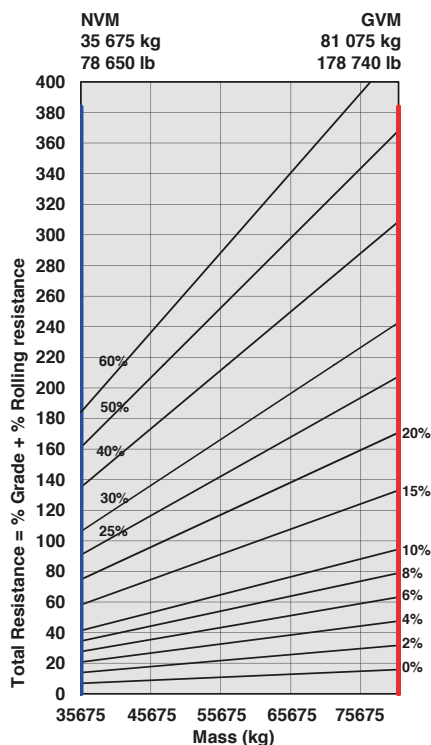

Retardation

1. Determine retardation force required by finding intersection of vehicle mass line.
2. From this intersection, move straight right across charts until line intersects the curve. NOTE: 2% typical rolling resistance is already assumed in chart.
3. Read down from this point to determine maximum speed.

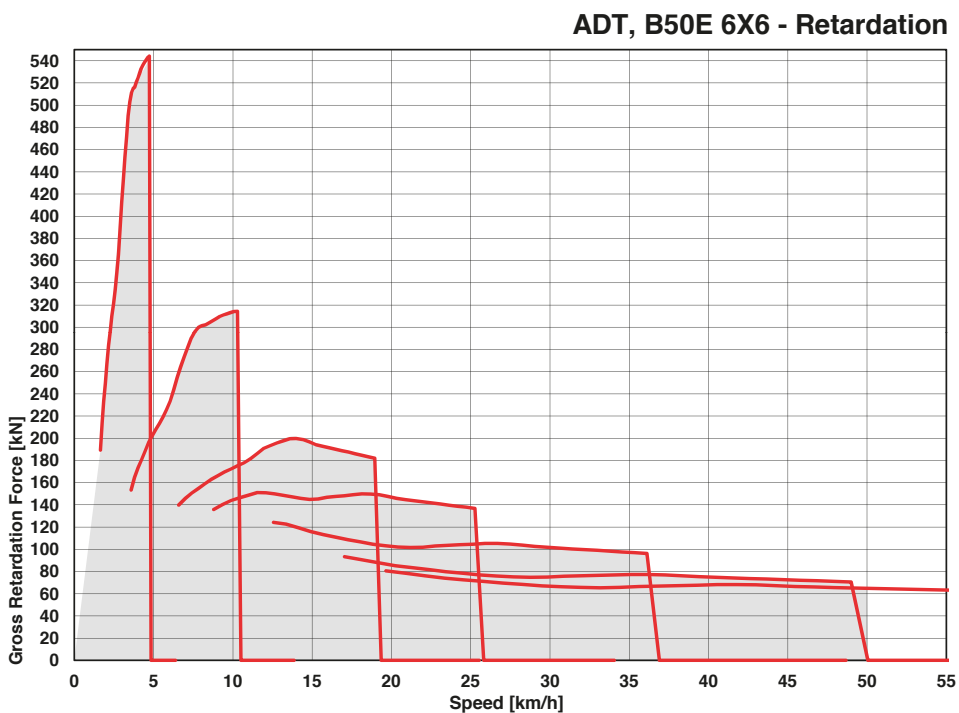
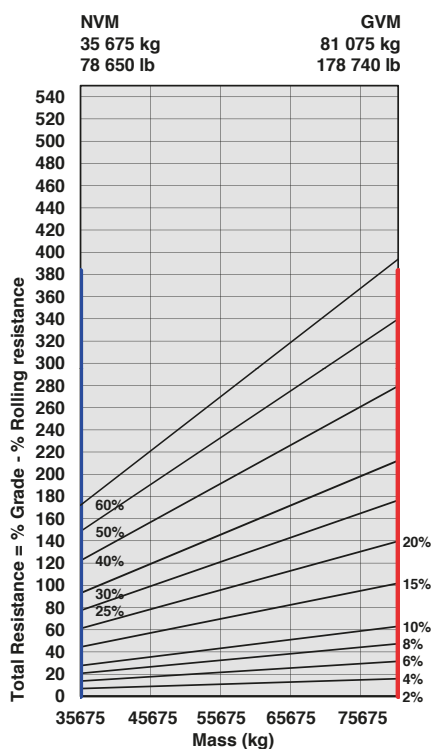

B35E	B40E	B45E	B50E		B35E	B40E	B45E	B50E	
				ENGINE					CAB (continued)
●	●	●	●	Jacobs Engine Brake®					Manually adjusted mirrors
●	●	●	●	Dual element air cleaner with dust ejector valve					Heated mirrors
●	●	●	●	Precleaner with automatic dust scavenging	●	●	●	●	Electrically adjusted and heated mirrors
●	●	●	●	Water separator	●	●	●	●	Deluxe 10" colour LCD:
●	●	●	●	Serpentine drive belt with automatic tensioner					Speedometer / Fuel gauge /
●	●	●	●	Provision for fast fill					Transmission oil temperature gauge /
●	●	●	●	Wet-sleeve cylinder liners					Engine coolant temperature gauge /
				COOLING					LED function/warning indicators and
●	●	●	●	Crankshaft mounted electronically controlled viscous fan drive					audible alarm / Transmission gear selection /
●	●	●	●	Fan guard					Tachometer / Battery voltage / Hour meter /
				PNEUMATIC SYSTEM					Odometer / Fuel consumption / Tip counter /
●	●	●	●	Engine-mounted compressor	●	●	●	●	Trip timer / Trip distance / Metric/English units /
●	●	●	●	Air drier with heater					Service codes/diagnostics
●	●	●	●	Integral unloader valve					Backlit sealed switch module functions with:
				ELECTRICAL SYSTEM					Wiper control / Lights / Heated mirrors /
●	●	●	●	Battery disconnect					Retarding aggressiveness / Transfer case
●	●	●	●	Halogen drive lights					differential lock / Transmission gear hold /
▲	▲	▲	▲	LED drive lights					Dump-body tip limit / Automatic dump-body
●	●	●	●	Air horn					tip settings / Airconditioner/ Heater controls /
●	●	●	●	Reverse alarm					Preselected Speed Control
▲	▲	▲	▲	White noise reverse alarm					DUMP BODY
●	●	●	●	Rotating beacon	●	●	●	●	Dump body mechanical locks (x2). Partially up
●	●	●	●	Pitch Roll Sensor					and fully up
●	●	●	●	Halogen Artic reverse light	▲	▲	▲	▲	Body liner
▲	▲	▲	▲	LED Artic reverse light	▲	▲	▲	▲	Tailgate
●	●	●	●	LED reverse lights	▲	▲	▲	▲	Body heater
				STEERING SYSTEM	▲	▲	▲	▲	Less dump body and cylinders
●	●	●	●	Bi-directional ground-driven secondary steering pump	▲	▲	▲	▲	Low SG bin extensions
				CAB	▲	▲	▲	▲	Bin pole lockout
●	●	●	●	ROPS/FOPS certification					OTHER
●	●	●	●	Tilt cab	●	●	●	●	Automatic Traction Control (ATC)
●	●	●	●	Gas strut-supported door	●	●	●	●	Wet disc brakes
●	●	●	●	I-Tip programmable dump-body tip settings	●				26.5 R 25 Radial Earthmover tyres
●	●	●	●	HVAC Climate control system		●	●	▲	29.5 R 25 Radial Earthmover tyres
●	●	●	●	AM/FM radio with Aux + USB		▲	▲	●	875/65 R 29 Radial Earthmover tyres
●	●	●	●	Rear window guard	●	●	●	●	Remote grease banks
●	●	●	●	Wiper/washer with intermittent control	▲	▲	▲	●	Automatic greasing
●	●	●	●	Tilt and telescoping steering wheel	●	●	●	●	Onboard weighing
●	●	●	●	Centre-mount air-suspension seat	▲	▲	▲	▲	Load lights: stack
●	●	●	●	Halogen work lights	▲	▲	▲	●	Comfort ride suspension (Front)
▲	▲	▲	▲	LED work lights	▲	▲	▲	▲	Comfort ride suspension (Rear)
▲	▲	▲	▲	Rotating beacon: seat belt installation	●	●	●	●	Reverse camera
▲	▲	▲	▲	Remote engine and machine isolation	●	●	●	●	Hand rails
●	●	●	●	Remote battery jump start	●	●	●	●	Cab peak
●	●	●	●	Retractable 3 point seat belt	▲	▲	▲	▲	High pressure hydraulic filter
●	●	●	●	Heated seat	▲	▲	▲	▲	Fuel heater
●	●	●	●	Foldaway trainer seat with retractable seat belt	●	●	●	●	Belly cover
●	●	●	●	12-volt power outlet	▲	▲	▲	▲	Remote transmission filters
●	●	●	●	Cab utility bin (removable)	●	●	●	●	Engine and transmission remote drain-gravity
●	●	●	●	Cup holder	▲	▲	▲	▲	Engine and transmission remote drain-scavenge
●	●	●	●	Cooled/heated lunch box	▲	▲	▲	▲	Window smash button
					●	●	●	●	High visibility mirrors
					●	●	●	●	Fleetm@tic® Classic Package for 2 years
					●	●	●	●	Electronic bonnet opening





All dimensions are shown in millimetres, unless otherwise stated between brackets. Under our policy of continuous improvement, we reserve the right to change technical data and design without prior notice. Photographs featured in this brochure may include optional equipment. Blu@dVantage™ is a trademark of Bell Equipment Co. (PTY) Ltd AdBlue® is a registered trademark of VDA.

BELL INTERNATIONAL: Tel: +27 (0)35-907 9431

E-mail: marketing@bellequipment.com

Web: www.bellequipment.com

 Tel: +61 (0)8-9355-2442

 Tel: +33 (0)5-55-89-23-56

 Tel: +49 (0)6631 / 91-13-0

 Tel: +7-495-287-80-02

 Tel: +27 (0)11-928-9700

 Tel: +44 (0)1283-712862

 Tel: +1 (704) 655 2802

**Strong Reliable Machines
Strong Reliable Support**

BELL

• A636E30 • A640E30 • A645E30 • A650E30